

# Drip Edge

ANSI/SPRI ES-1 CERTIFIED: .040" Aluminum = 410 psf, 24GA Steel = 390 psf

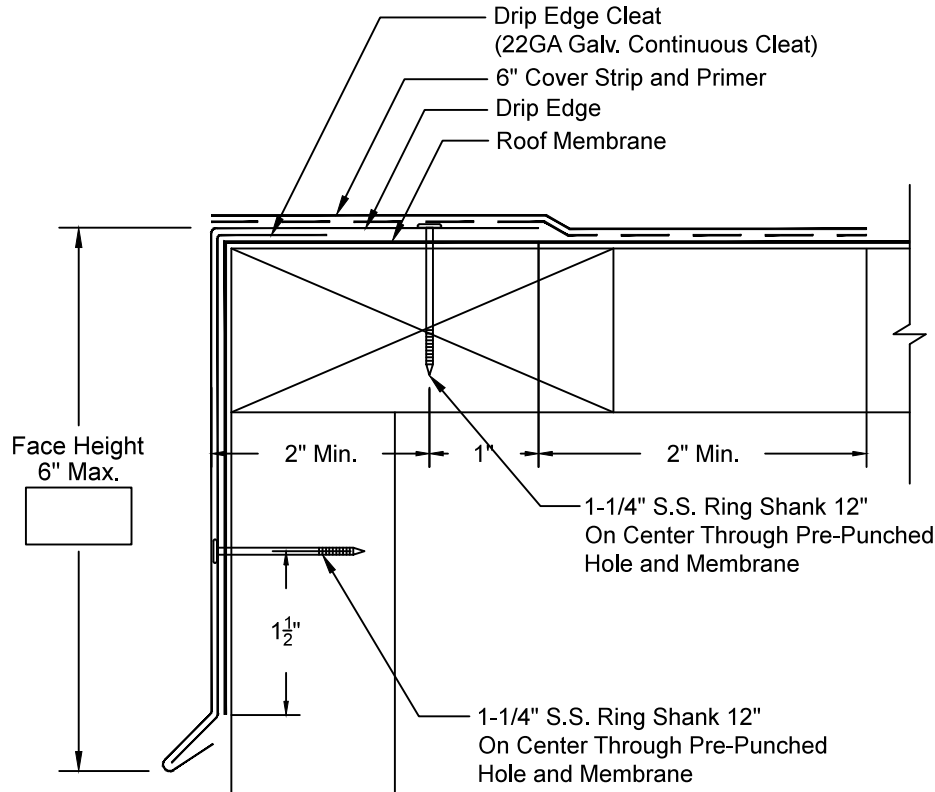

- Continuous Cleat and fasteners provided.
- Concealed Splice Plates provided.
- Splice Plate Sealant available for extra charge.

## QUANTITIES:

Lineal Feet (10'-0" Lengths\*): \_\_\_\_\_

Outside Miters\*\* : \_\_\_\_\_  Optional Welded (Surcharge Applies)

Inside Miters\*\* : \_\_\_\_\_  Optional Welded (Surcharge Applies)

Right End Caps\*\* : \_\_\_\_\_  Optional Welded (Surcharge Applies)

Left End Caps\*\* : \_\_\_\_\_  Optional Welded (Surcharge Applies)

Splice Plate Tape Sealant:  Optional Sealant (Surcharge Applies)

\* Optional lengths available up to 20'-0"

\*\* Standard riveted

## PRINT APPROVAL:

Architect and/or Contractor shall verify all dimensions, sizes, and quantities, All products to be installed in strict accordance with Drexel's printed instructions.

Approved By: \_\_\_\_\_

Date: \_\_\_\_\_

PROJECT:

ARCHITECT:

ROOFING CONTRACTOR:

REPRESENTATIVE:

## MATERIAL:

24GA  .040" AL

Other: \_\_\_\_\_

Finish: \_\_\_\_\_

Color: \_\_\_\_\_

Effective Date: 5-1-13

Drawn By: J.S.

Approved By: B.P.



P: 800-628-5849 E: office@garretymfg.com W: www.garretymfg.com